

# Smart Battery Charger

**Automatic 7 stage battery charger with switching mode**

**12V 10A, 24V5A, 12V20A, 24V10A, 12V30A, 24V15A,  
12V40A, 24V20A, 12V50A, 24V25A, 12V60A, 24V30A**

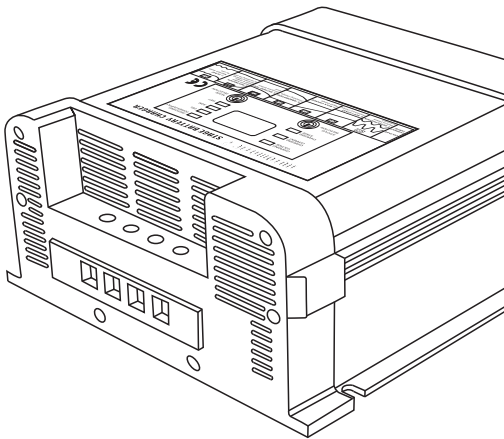

※ THE IMAGE SHOWN HERE IS INDICATIVE ONLY, PLS REFER TO THE ACTUAL PRODUCT.

## 1. Important information

Thank you for purchasing our smart battery charger. Please read this instruction manual carefully before operating the device. Keep this manual in a safe place for future reference. This instruction manual is a part of the product. It must be handed over along with the device if it is passed on to a third party.

## 2. Introduction

This compact smart battery charger uses the latest switch-mode technology and it designed particularly to charge lead-acid batteries in dual battery system to their best level. The automatic 7 stage charging algorithm delivers a more efficient and full charging without the issue of voltage drops. Thanks to the boost-charging feature, this helps to activate the battery status and wake up a weak or flat battery to a suitable recharging level. This also improves the charge delivered to your battery, increases the service life of battery and prevents premature battery failure.

This smart battery charger can be used to charge GEL/AGM/WET batteries by pressing the mode selection button. And this smart battery charger can be used as a constant power supply (Switching power supply function) to run devices that require a stable and clean DC voltage. When charge lithium battery, please set the charger to lithium battery charging mode by pressing the MODE SELECTION button and will see the LED turning green. The LCD will display charging voltage , charging current and charging stage, the data are set as customer required. For safety reasons, the input and output of the charger are completely isolated and the batteries are protected from being overcharged.

The cooling fan is thermal & charge current dual controlled, when temperature reaches up to 45 degrees centigrade or when charge current is up to 2A, the cooling fan start working, it will switch on and off automatically to control the internal temperature of the unit.

Only when this smart battery charger be connected to battery, then the charger has DC output start to charge. Note: it is a touch-type battery charger, the first start battery voltage for constant current mode need up to 12.6V.

DC short circuit protection: after short circuit protection, cut off the DC output, LCD display "- P-", the battery charger will reset automatically when short circuit faults remove.

Over heat protection: when temperature reaches to  $75 \pm 5$  °C , the LCD display "-P-", when the temperature drops, the battery charger will reset automatically.

## 3. Warning

Risk of electric shock! Do not open the device if it has been connected to the AC power source.

4.  This device has been CE tested and conforms to the applicable directives and standards.

### 5. The battery charger materials list and indication

There are smart charger unit, user manual, AC power cable and spare fuse inside of packing.

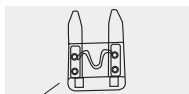
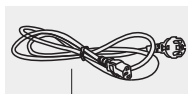
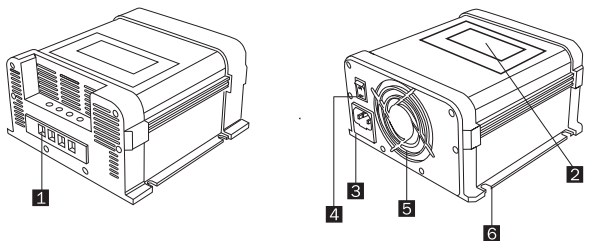

- 1. Battery charging output
- 4. Power on/off switch
- 7. AC power cable

- 2. LCD display
- 5. Cooling fan
- 8. Fuse

- 3. AC input terminal
- 6. Mounting hole

### The LCD screen display and button function

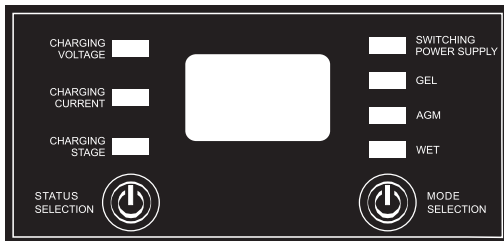

- 5.1 Charging voltage LED: If you want to know the charging voltage, please press the status selection button until the charging voltage LED light on, then LCD screen displays the charging voltage of the charger.
- 5.2 Charging current LED: If you want to know the charging current, please press the status selection button until the charging current LED light on, then the LCD screen displays the charging current of charger.
- 5.3 Charging stage LED: If you want to know the charger in which charging stage, please press the status button until the charging stage LED light on, then the LCD screen displays which charging stage the charger is in. There are total 7 different charging stages.
- 5.4 Status selection button: By long pressing the "status selection" button to change the LCD screen display the charging voltage, charging current or different charging stages.
- 5.5. Switching power supply LED: If you want to use this charger as a switching power supply unit, please press the mode selection until the switching power supply LED light on. There are three colors in switching power supply mode. Green- 13.2V, red- 13.4V, orange- 13.8V.
- 5.6 GEL/AGM/WET batteries charging LED: By pressing the mode selection button to set the battery type.
- 5.7 Mode selection button: By long pressing the button to change this smart charger to switching power supply function or setting GEL, AGM or WET batteries type.
- 5.8 LCD screen display: It shall automatically circularly display the charging voltage, current and different charging stage. When overheat and short circuit protection, the LCD displays "-P-". The screen display time is 60s. When there is no operation, the screen will go out automatically and will lit again by pressing the button.

## 6. 7-stage automatic charging

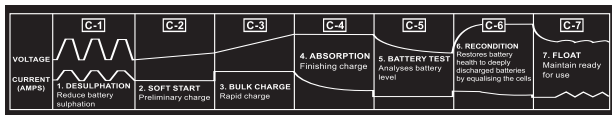

This is a fully automatic battery charger with 7 charging stages.

Automatic charging protects your battery from being overcharged. So you can leave the charger connected to the battery indefinitely.

7-stage charging is a very comprehensive and accurate charging process that gives your battery longer life and better performance compared to using traditional chargers.

7-stage chargers are suitable for most battery types including GEL, AGM, WET batteries. They may also help to restore drained and sulphated batteries.

The 7 stages are:

Desulphation; Soft start; Bulk charge; Absorption; Battery test; Recondition; Float

**Desulphation:** The desulphation stage breaks down sulphation that occurs in batteries which have been left flat for extended periods of time, bringing them back to be fully charged. Sulphation occurs when lead-sulphate hardens and clogs up to battery cells.

**Soft start:** A preliminary charging stage that introduces the half of the rated current to the battery slowly. The stage can protect the battery and extend the life of battery.

**Bulk charge:** Charging with maximum current until the battery capacity approaches approximately 80%.

**Absorption:** The charging current gradually decreases during charging and the battery capacity approaches 100%.

**Battery test:** Test the battery and find out whether the battery can save power or not. If not, please replace another battery.

**Recondition:** Choose the second program to add the second step to the charging process. During the second step, voltage increases to create controlled gassing in the battery. Gassing mixes the battery acid and restores the battery.

**Float:** The float stage maintains 100% battery capacity without discharging. This means the charger can be left connected to the battery indefinitely. The battery charger has a 7-stage fully automatic charging curve, the cycle is repeated infinitely. When the terminal voltage drops below the lowest limit, the charger will automatically go back to the beginning of the charging curve.

## 7. Caution!

- 7.1 The device is for indoor environment, do not use the device near flammable materials or in any location that may accumulate flammable fumes or gases.
- 7.2 Appliance shall only be used with rated voltage and frequency.
- 7.3 The surface of the battery will become hot when operating, especially at full load condition.
- 7.4 Make sure the polarity is correct.
- 7.5 Do not put the device on the top of the battery. Especially wet type battery. It may generate gas vapor while charging.
- 7.6 Do not charge non-rechargeable batteries.
- 7.7 Use the device only in the described manner.
- 7.8 The device should not be exposed to heat source, such as direct sunlight or heating.
- 7.9 Store the device in a dry and cool place.
- 7.10 Do not open, no any user serviceable parts inside.

## 8. Using Steps

- 8.1 First connect the smart charger to the battery, switch on the charger, then the charger starts charging the battery. It is with 7-stage charge function. The LCD display circulates automatically. When overheat and short circuit protection, the LCD screen displays "-P-".
- 8.2 The screen display time is 60s. When there is no operation, the screen will go out

automatically and will be lit again by pressing the button.

8.3 Long press the button 'MODE SELECTION' to change the mode.

Note: there are three colors of indicators in switching power supply mode. Green- 13.2V, red- 13.4V, orange- 13.8V

8.4 By pressing the 'STATUS SELECTION' button to change the LCD display.

## 9. Trouble shooting

Problems and symptoms	Possible cause	Solutions
No DC output or charger cannot startup	No AC input	Check the AC power source
	Overheat shutdown	Cool down the device.
	Bad contact of battery terminal	Check the connection between charger and battery
	Output short circuit	
Battery charging not stable	AC input voltage is not stable	Check whether the AC voltage is in the range of the voltage
	Choose the improper battery	Select the proper battery
Charger cannot switch to float	Battery cable connected to the battery is too thin	Change cable of proper size
	Battery in poor condition	Replace new battery

## 10. Safety operation!

- 10.1 If the cable need be put through the walls with sharp edges, always use tubes or ducts to prevent damage.
- 10.2 Do not pull on the cables, fasten the device and cable securely. Lay the cable so that it cannot be tripped over.
- 10.3 Ensure the device standing firmly that it cannot be tipped over or fall down.
- 10.4 Ensure child is away from the device.
- 10.5 Ensure no water, drip or splash on the device.
- 10.6 Ensure the air inlets and outlets of the device are not covered.
- 10.7 Ensure the housing and the connection cables are undamaged before operating the device.
- 10.8 Do not reverse the polarity of the connection to the battery.
- 10.9 Disconnect the power supply before making or cutting the connections to the battery.
- 10.10 Warning! There is risk of electric shock! Do not open the device when connected to AC power.

## 11. Specification

Model	EBC1210	EBC2405	EBC1220	EBC2410
Input voltage range	190-265V AC ~ 50Hz			
Bulk/Absorption charging	14.2V/14.6/14.8V DC selectable (12V) 28.4V/29.2/29.6V DC selectable (24V)			
Float charging	13.2V/13.5/13.8V DC selectable (12V) 26.4V/27V/27.6V DC selectable (24V)			
Max. DC output current	10A	5A	20A	10A
Output voltage	12V	24V	12V	24V
Suggest battery capacity	15-100Ah		25-200Ah	
Output ripple	<50mA at full load			
Max. efficiency	88%			
Load regulation	1.5% at output current; no load to full load			
Optimum ambient temperature	0-40°C			
Isolated DC output	2			
Ventilation	Cooling fan ; By thermal & current controlled			
Dimensions(mm)	176x175x95 (LxWxH)			

Model	EBC1230	EBC2415	EBC1240	EBC2420
Input voltage range	190-265V AC ~ 50Hz			
Bulk/Absorption charging	14.2V/14.6/14.8V DC selectable (12V) 28.4V/29.2/29.6V DC selectable (24V)			
Float charging	13.2V/13.5/13.8V DC selectable (12V) 26.4V/27V/27.6V DC selectable (24V)			
Max. DC output current	30A	15A	40A	20A
Output voltage	12V	24V	12V	24V
Suggest battery capacity	40-300Ah		50-400Ah	
Output ripple	<50mA at full load			
Max. efficiency	88%			
Load regulation	1.5% at output current; no load to full load			
Optimum ambient temperature	0-40°C			
Isolated DC output	2			
Ventilation	Cooling fan ; By thermal & current controlled			
Dimensions(mm)	226x175x95 (LxWxH)			

Model	EBC1250	EBC2425	EBC1260	EBC2430
Input voltage range	190-265V AC ~ 50Hz			
Bulk/Absorption charging	14.2V/14.6/14.8V DC selectable (12V) 28.4V/29.2/29.6V DC selectable (24V)			
Float charging	13.2V/13.5/13.8V DC selectable (12V) 26.4V/27V/27.6V DC selectable (24V)			
Max. DC output current	50A	25A	60A	30A
Output voltage	12V	24V	12V	24V
Suggest battery capacity	40~300Ah		80~500Ah	
Output ripple	<50mA at full load			
Max. efficiency	88%			
Load regulation	1.5% at output current; no load to full load			
Optimum ambient temperature	0-40 °C			
Isolated DC output	2			
Ventilation	Cooling fan ; By thermal & current controlled			
Dimensions(mm)	226x175x95 (LxWxH)			

#### Battery type and charging voltage setting

Battery type	Float charging		Bulk/Absorption charging	
	12V	24V	12V	24V
GEL /SLA	13.2V	26.4V	14.2V	28.4V
AGM	13.5V	27V	14.6V	29.2V
WET/calcium	13.8V	27.6V	14.8V	29.6V

## 12. Warranty

The cost of parts and repair service only be covered by CARSPA within the warranty period. Warranty will not apply to the device which have been internal or external damaged resulting from improper use(improper operation or not in the optimal environment), improper installation or being altered. If the device requires warranty service, please return it to the place of purchasing along with the copy of the receipt with purchasing date.



### Disposal

When the device has become unusable, dispose of it in accordance with the appliance disposal regulations.